

KBN135 Series

HYUNDAI WIA Heavy Duty Boring Machine

www.wardcnc.com

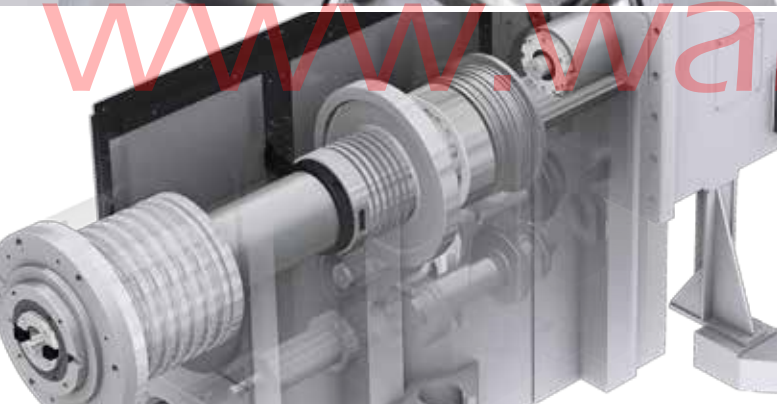



www.wardcnc.com

Technical Leader

The Heavy Duty Boring Machine KBN135/KBN135C, designed by Hyundai WIA with years of expertise and the latest technology, provides high performance and maximum productivity.



KBN135

[Option] [SIEMENS]

Pallet Size	mm(in)	2,000×1,800 (78.7"×70.9")
Max. Load Capacity	kg(lb)	10,000 (22,046.2)
Min. Indexing Angle	deg	0.001° / 90° (LOCATING PIN)
Spindle Quill Diameter	mm(in)	Ø135 (5.3")
Spindle Taper	-	NT #50
Spindle Speed	rpm	2,000 [2,000] [2,000] [2,000]
Spindle Power	kW(HP)	22 (29.5) [26 (34.9)] [37 (49.6)] [37 (49.6)]
Spindle Driving Method	-	3 Step Gear
No. of Tools	EA	40 [60, 90, 120]
Travel(X/Y/Z/W)	mm(in)	3,000/2,000/1,600/700 (118.1"/78.7"/63"/27.6") [4,000/2,500/1,600/700 (157.5"/98.4"/63"/27.6")]
Rapid Traverse Rate	m/min(ipm)	8/8/8/8 (315/315/315/315)

KBN135C

[Option] [SIEMENS]

Pallet Size	mm(in)	2,000×1,800 (78.7"×70.9")
Max. Load Capacity	kg(lb)	15,000 (33,069) [20,000 (44,093)]
Min. Indexing Angle	deg	0.001° / 90° (LOCATING PIN)
Spindle Quill Diameter	mm(in)	Ø135 (5.3")
Spindle Taper	-	NT #50
Spindle Speed	rpm	2,500 [2,500] [2,500] [2,500]
Spindle Power	kW(HP)	22 (29.5) [26 (34.9)] [37 (49.6)] [37 (49.6)]
Spindle Driving Method	-	3 Step Gear
No. of Tools	EA	40 [60, 90, 120]
Travel(X/Y/Z/W)	mm(in)	3,000/2,000/1,600/700 (118.1"/78.7"/63"/27.6") [4,000/2,500/2,000/700 (157.5"/98.4"/78.7"/27.6")]
Rapid Traverse Rate	m/min(ipm)	10/10/10/8 (393.7/393.7/393.7/315)

www.wardcnc.com

www.wardcnc.com



KBП135

The Next Generation Boring Machine
To Revolutionize Productivity

KBN135 Series

- One-piece bed construction for ultra precision (KBN135)
- Movable column structure for high-load, heavy load and heavy duty cutting (KBN 135C)
- X/Y-axis expansion up to 1,000mm (39.4") and 500mm (19.7") respectively
- 3 step gear driven spindle for heavy duty cutting
- Optimal boring processing with W-axis travel of 700mm (27.6")
- Linear scale and rotary scale for ultra precision
- Position Encoder on B-axis for highly precise positioning



KBN135C





Heavy Duty CNC Boring Machine

KBN135 series features linear scales and a gear driven spindle for high precision and superb heavy duty cutting ability.

HYUNDAI WIA
MACHINE TOOL

KBN135 SERIES
Heavy Duty Boring Machine

04
+
05

01

KBN135 Series

Basic Features

The Most Advanced Mechanism,
Revolutionized Productivity & High Performance

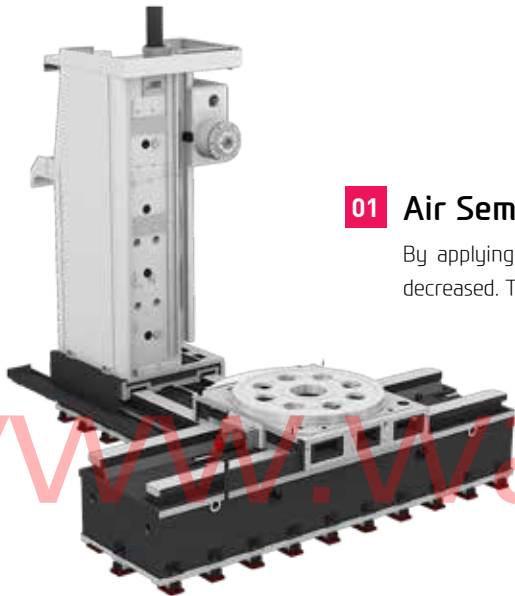

01 Air Semi-Rising Slide Way

By applying the **Air Semi-Rising Sliding Ways**, the load on the X/Z-axis slideway is decreased. Therefore, positioning and repeatability accuracy can be maintained for a long time.

Linear & Rotary Scales on All Axes (Standard)

Linear scales on X/Y/Z-axis and rotary scale on B-axis provide High accuracy positioning and enabling precise machining.

Linear Scale



Rotary Scale



Fully Protected Slidecover

Slidecover of each axis is fully protected from chips and debris.



02

Spindle

KBN135 series is designed with a 3 step gear drive, which provides high torque at low rpm and stability at high rpm.

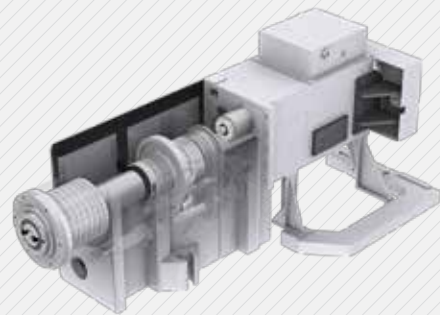

03

Table

KBN135 series is the most optimal machine for fixturing and machining of large workpieces. It has best in class machining area and load capacity.

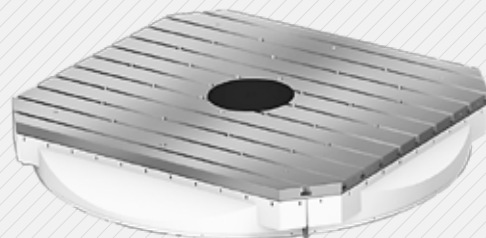

04

www.wardcnc.com

Convenient Maintenance

Oil and Air devices are located in front of the machine for easy repair and maintenance.



KBN135C (Column Moving Type)

The column moving Z-axis enables precise machining of large work and prevents sagging of table when loading or machining.

Also, table column separate structure provides high rigidity.

KBN135 (Table Moving Type)

The one-piece bed structure of X/Z-axis helps maintain high accuracy and makes it easier to adjust the machine for better precision.



N2

KBN135 Series

High Precision Spindle

Cutting Edge Design & Optimized Cutting Condition
Heavy Duty Boring Machine

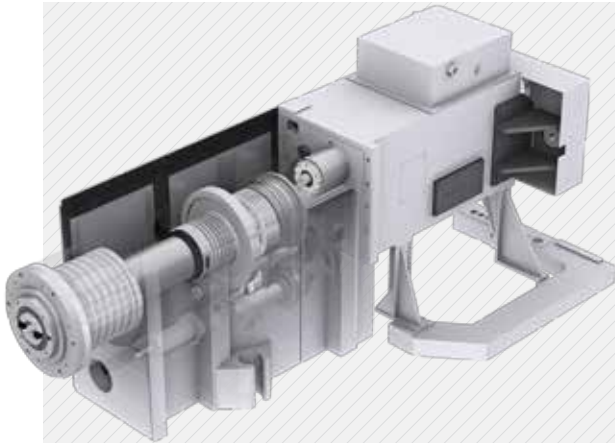

Spindle

By using ultra precision cylindrical roller bearings, fast acc/ deceleration of the spindle is achieved.

The spindle head is designed to minimize the thermal displacement of the spindle, and with the use of a hydraulic tool locking system the machining stability is increased.

Gear Type Spindle

KBN135 series is designed with a 3 step gear driven spindle, providing high torque at low speed and stable machining at high speed.

Through Spindle Coolant **OPTION**

Through spindle coolant is particularly useful for deep hole drilling and helps increase tool life and decrease cycle time.

20 bar (290 psi)

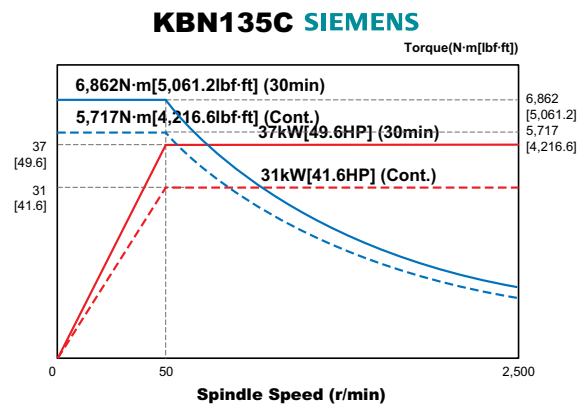
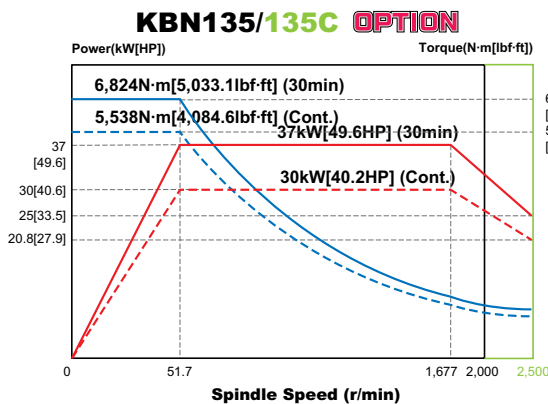
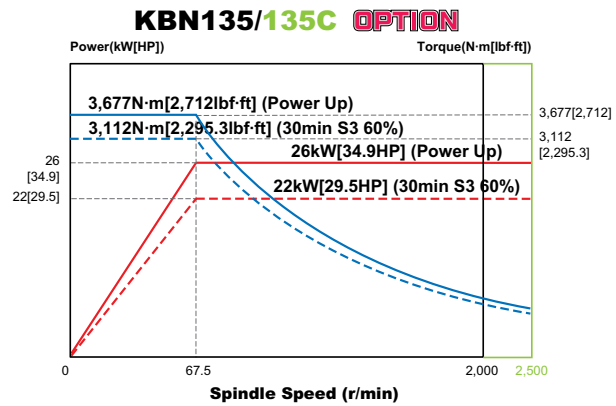
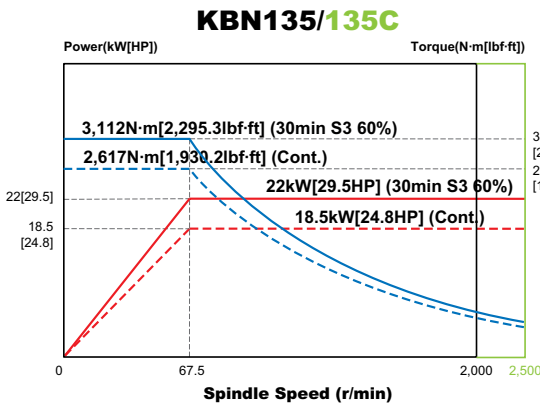

Special Head **OPTION**

Specifications	
Length	500 mm (19.7")
Spindle Speed	500 rpm
Speed Ratio	1:1
Lubrication	Grease
Tool Change	Manual
Tool Shank	BT50
Tool Clamping	Bolting (M24)
Max. Tool Weight	20 kg (44.1 lb)
Machine Weight	230 kg (507 lb)

Angle Head Specifications

- Length : 500 mm(19.6"), 800 mm(31.5")
- Angle : 90°, 180°, 270° or or any other customer needs

Angle Head (Manual)

Angle head comes with rotary body, which enables machining items that are set perpendicular to the spindle. It is connected to arbors that transfer the torque generated from the main spindle motors.



Specifications	
Radial Transverse	160 mm (6.3")
Max. Rotation	170 rpm
Body Diameter	Ø600 (Ø23.6")
ax. Cutting Diameter	Ø920 (Ø36.2")
Feed Ratio (Quill:Slide)	1:2
Clamping Bolt	4-M20
T-Slot Distance	190 mm (7.5")
Machine Weight	320 kg (705.5 lb)

Facing Head (Manual)

A facing head is attached to the cross section of the spindle for various types of operations; outer facing, inner facing, cylindrical and conical boring and threading etc.

It shows excellent performance in machining parts such as flange faces of large valves.



W-Axis Spindle

The W-axis travel of 700mm(27.6") contributes to the KBN135 series' reputation as among the very best boring machines.

Spindle Clamping Unit

A clamping unit is applied to the W-axis for extra support in heavy duty cutting.

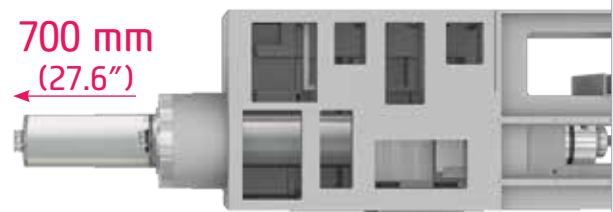

n3
KBN135 Series

Magazine & Table

High Productivity Achieved
with High Rigidity and Accuracy



www.wardenc.com

ATC & Magazine

KBN135 holds 40 tools as standard and maximum of 120 tools as an option. Fixed address tool selection method and a special controlling panel increase convenience.

(KBN135C : 40 Tool Standard / 60 Tool Option)

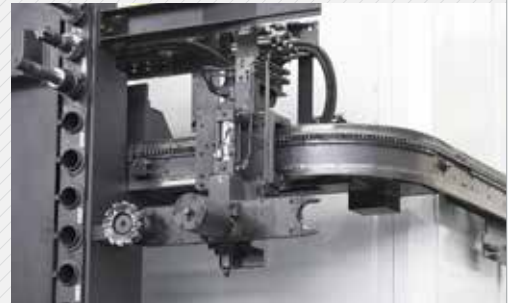

Machine Dimensions According to Magazine Selection (KBN135)

40 Tool : 6,900 mm(271.7") 60 Tool : 7,300 mm(287.4")
90 Tool : 8,275 mm(325.8") 120 Tool : 9,250 mm(364.2")

B-Axis Control NC Rotary Table

High ratio worm gear leads to high precision machining and **built-in position encoder** in B-axis enables precise rotation in 90° and 0.001° which is suitable for machining various shapes. Also it has the largest machining area and best load capacity in its class which enables easier work setting.

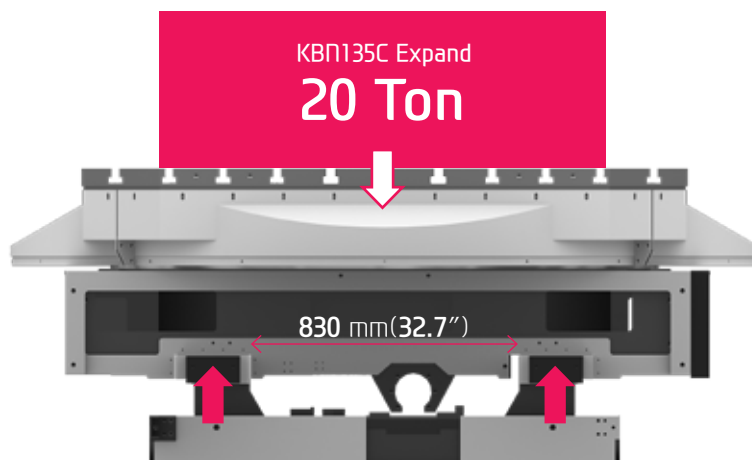

Table Size : 2,000×1,800 mm
(78.7"×70.9")

Max. Load Capacity

KBN135 : 10,000 kg (22,046.2 lb)
KBN135C : 15,000 kg (33,069.3 lb)
KBN135C Expand :
20,000 kg (44,092.4 lb)

(KBN135C | KBN135C Expand :
within 300mm(11.8") of the biased weight)

Mini. Indexing Angle

0.001° / 90° (Locating Pin)

B-Axis Spur Gear (KBN135C | KBN135C Expand)

The B-axis is driven by a spur gear to improve productivity, and increase the table positioning speed.

(KBN135C : 2 rpm, KBN135C Expand Option : 1 rpm)



04

KBN135 Series

Machining Area

The Best Performance, Powerful Cutting
CNC Boring Machine

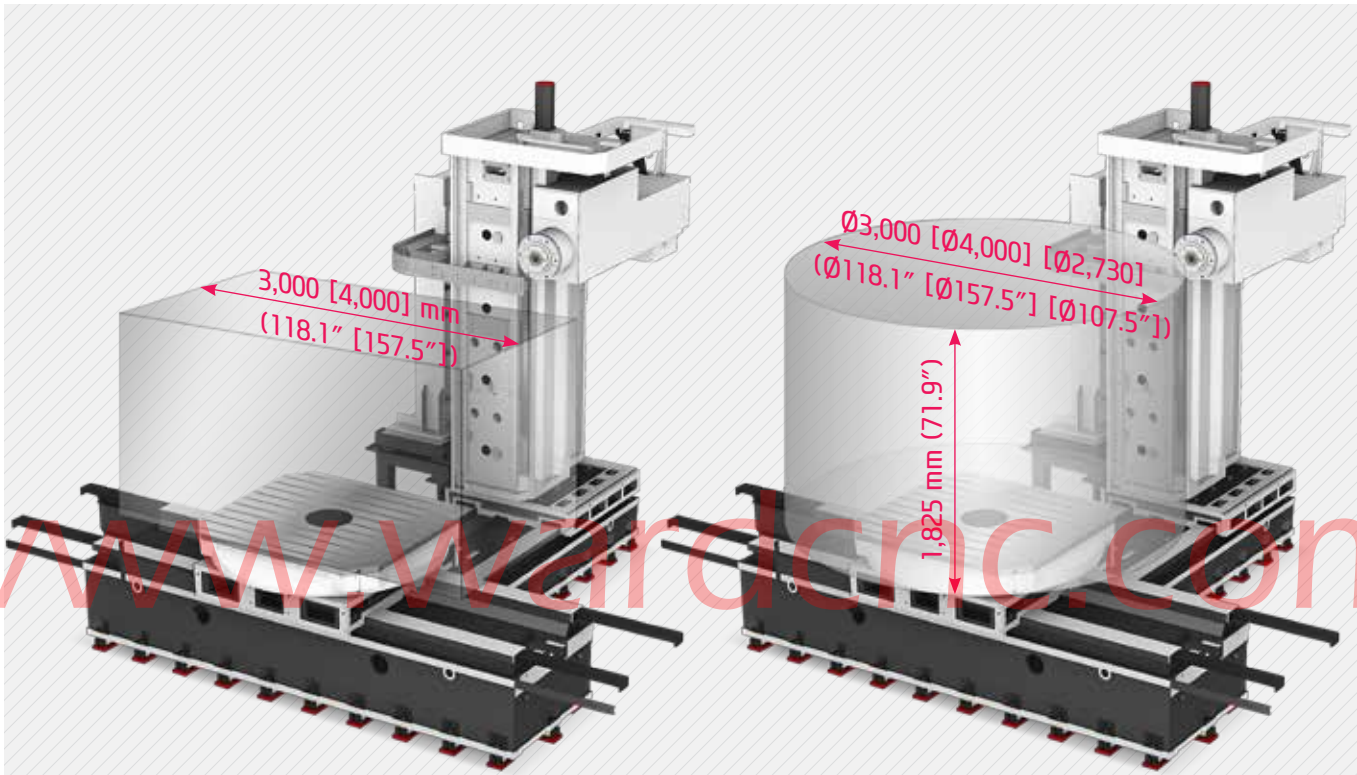

Expansion of Machining Area **OPTION**

KBN135

ITEM	X-axis	Y-axis	Z-axis	W-axis
Standard	3,000 (118.1")	2,000 (78.7")	1,600 (63")	700 (27.5")
Expansion	4,000 (157.4")	2,500 (98.4")	↑	↑

KBN135C

ITEM	X-axis	Y-axis	Z-axis	W-axis
Standard	3,000 (118.1")	2,000 (78.7")	1,600 (63")	700 (27.5")
Expansion	4,000 (157.4")	2,500 (98.4")	2,000 (78.7")	↑

Optional Specific Processing Area

Division	Max. Width	Max. Dia.	Remark
Non Table Around Cover	X-Axis Standard : 3,000 (118.1")	X-Axis Standard : Ø3,000 (Ø118.1")	Standard
	X-Axis Expansion : 4,000 (157.4")	X-Axis Expansion : Ø4,000 (Ø157.4")	Option
Table Around Cover	X-Axis Standard : 3,000 (118.1")	X-Axis Standard : Ø2,940 (Ø115.7")	Option
	X-Axis Expansion : 3,550 (140")	X-Axis Expansion : Ø2,940 (Ø115.7")	Option
Coolant splash cover	2,730 (107.5")	Ø2,730 (Ø107.5")	Option

Machining Area

KBN135 / KBN135C

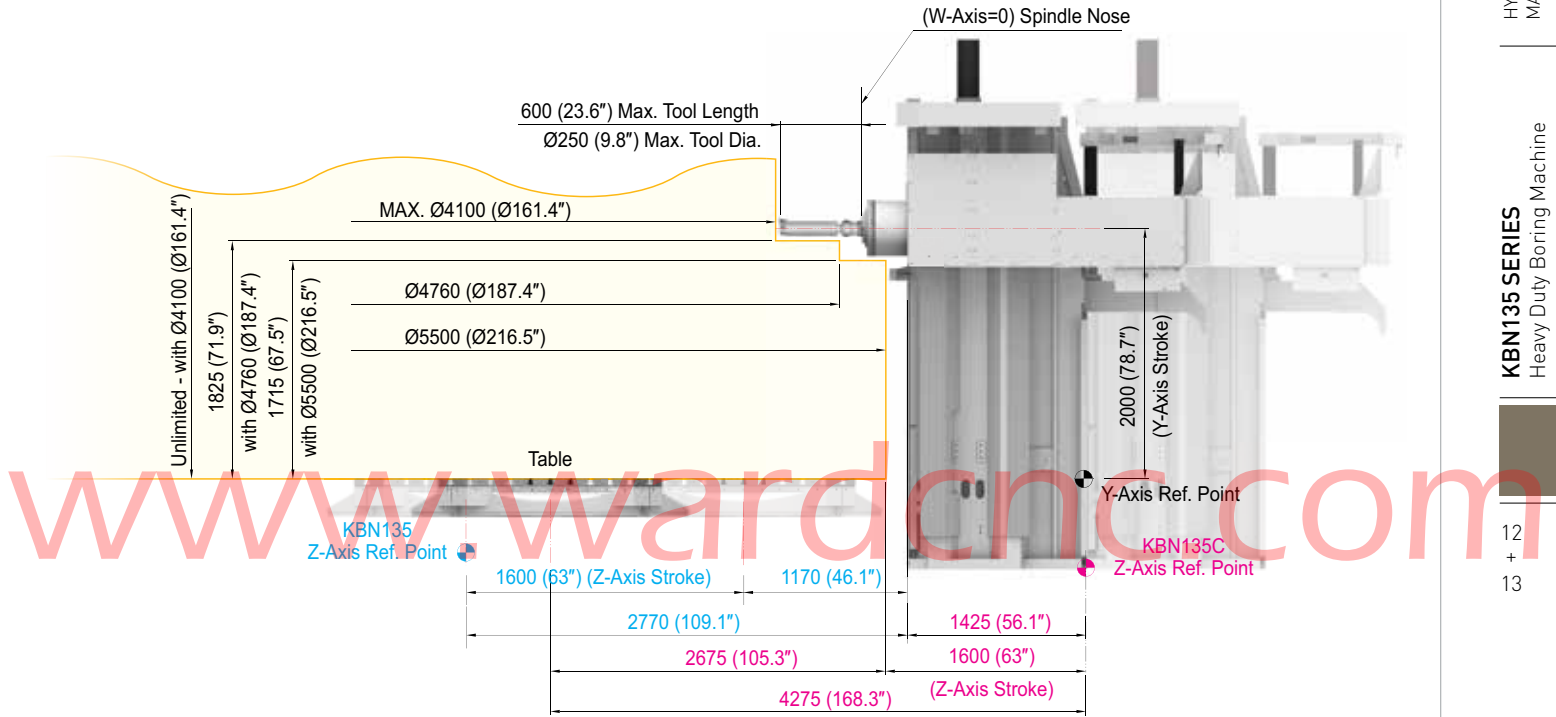

HYUNDAI WIA
MACHINE TOOL

KBN135 SERIES
Heavy Duty Boring Machine

12
+
13

Face Milling Capability (KBN135)

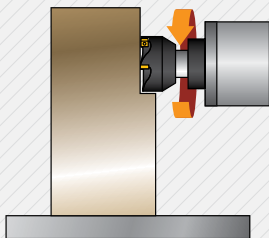

Quill : 0 mm

Speed	450 rpm
Cutting depth	6 mm
Feed	320 mm/min
No. of blades	10 ea
Tool Dia.	160 mm

SS400 (Rolled Structural Steel)

▶ Excellent Machined Quality

Quill : 300 mm (11.8")

Speed	450 rpm
Cutting depth	5 mm
Feed	320 mm/min
No. of blades	8 ea
Tool Dia.	160 mm

SS400 (Rolled Structural Steel)

▶ Excellent Machined Quality

❖ The above results might be different by types of processing circumstances.

05

KBN135 Series

Smart System



Software for Smart Operating and Machining

Faster processing and enhanced accuracy in are possible through the **HYUNDAI WIA Smart System**. The user friendly software and equipment monitoring of the Smart System maximizes productivity.

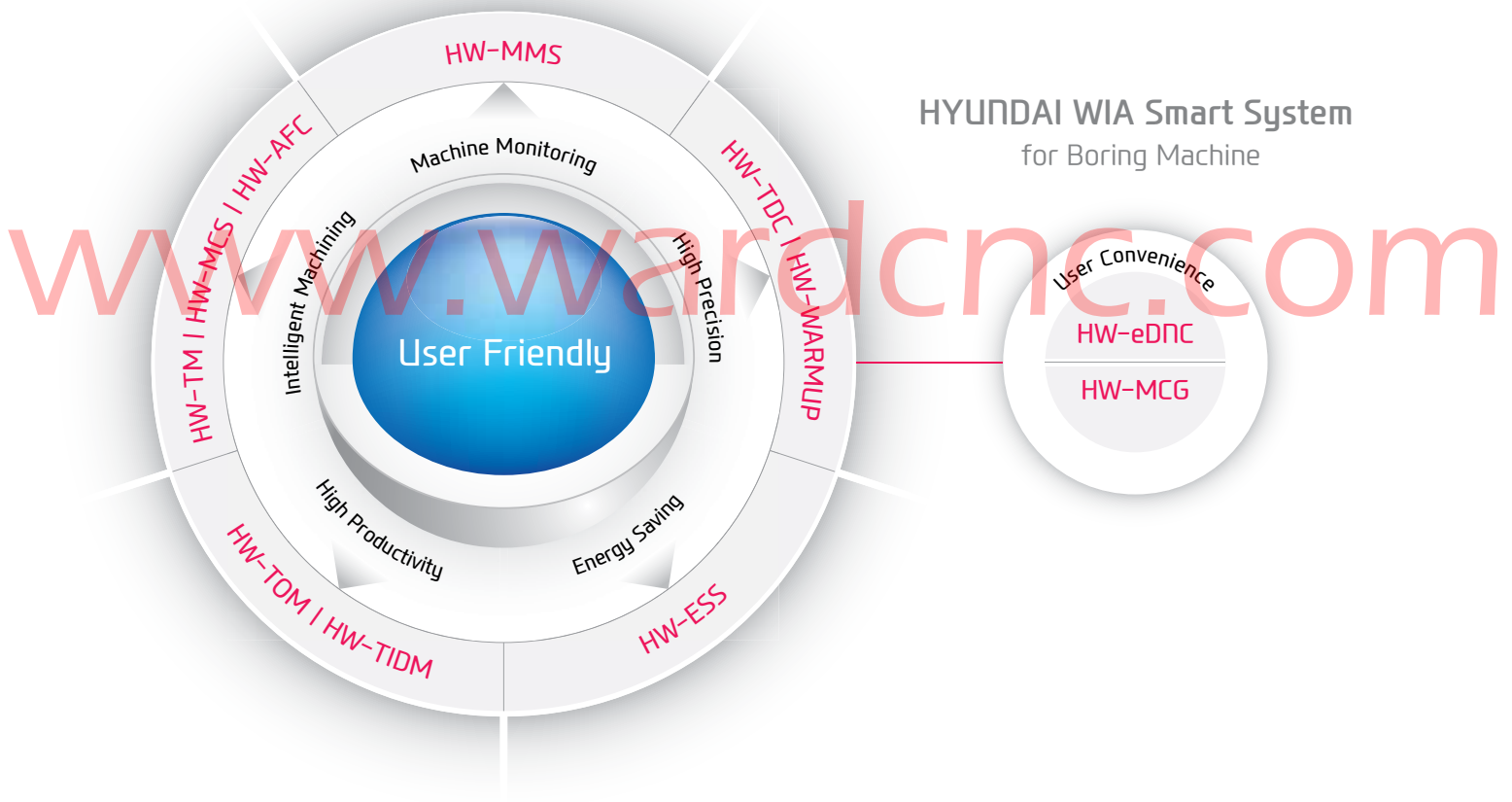

HYUNDAI WIA Smart System
for Boring Machine

User Friendly

Machine Monitoring

High Precision

Energy Saving

High Productivity

User Convenience

HW-eDNC

HW-MCG

HW-MMS

HW-TDC | HW-WARMUP

HW-ESS

HW-TM | HW-MCS | HW-AFC

HW-TOM | HW-TIDM



HW-AFC

HYUNDAI WIA
Adaptive Feed Control

(FANUC)

Software that controls the feed automatically to maintain a certain working load to extend tool life as well as productivity.



HW-MCS

HYUNDAI WIA
Machining Condition Selection

(FANUC)

Software that automatically sets cutting and feeding parameters according to the machining types (speed, degree, quality)

Smart Factory HW-MMS (HYUNDAI WIA-Machine Monitoring System)

A brand new manufacturing machine by HYUNDAI WIA, HW-MMS is a unique software capable of monitoring the operation status of manufacturing machines in factories, a smart solution to improve manufacturing conditions of customers.



- 01 Real-time monitoring of machine operation status (Cloud)
- 02 History and statistics of machine operation (Cloud)
- 03 History and statistics of alarm occurrence (Cloud)
- 04 History and statistics of work count (Cloud)
- 05 Remote diagnosis (Remote)

www.wardcnc.com



HW-MCG
HYUNDAI WIA
Machine Guidance

(FANUC)

Software that offers operation, maintenance, management monitoring and various user friendly features.

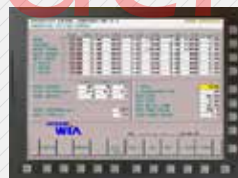

HW-TDC
HYUNDAI WIA Thermal
Displacement Compensation

Software that measures the changes in the external environment as well as heat emission during processing to help reduce thermal displacement.



HW-WARMUP
HYUNDAI WIA
WARMing Up

(FANUC)

Warm-up software that measures main spindle halt and offers system warm-up time automatically.



HW-ESS
HYUNDAI WIA
Energy Saving System

(FANUC)

An environmental friendly software that reduces the unnecessarily wasted standby power waiting for an operation.



HW-TOM
HYUNDAI WIA
Tool Offset Measurement

User friendly GUI software that indicates tool length, diameter, and damage (H/W excluded)



HW-TM
HYUNDAI WIA
Tool Monitoring

A tool monitoring software which analyzes the load of the spindle motor to determine and monitor possible damage of tools.

n6

KBN135 Series

User Convenience

Various Devices for User Convenience

Measuring Device **OPTION**

Touch Sensor

Workpiece coordinate values can be set automatically using the optional spindle probe.



TLM - Laser & Touch

Tool lengths and diameters can be set automatically using the optional tool setter. This can also be used to monitor attrition and detect broken tools.

Laser Type

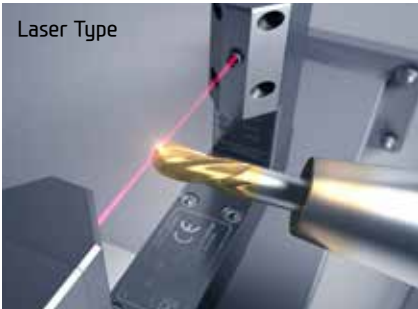

Touch Type



Chip Conveyor **OPTION**

Chip Disposal

Screw conveyors which is provided as standard makes chip disposal easier.



- **Hinge Belt Type** : Highly efficient when disposing a lot of chips. Capable of handling stringy chips.
- **Scraper Type** : Convenient for shortly cut chips.
- **Drum Filter Type** : Advantageous in precision, as the chips do not flow in to the coolant nozzle

Control Panel

Swing Type Control Panel

Swing type control panel minimizes unnecessary movement of workers and allows optimal control and handling. Also, movable MPG which is standard adds even more accessibility to workers.

KBN135 >>



KBN135C >>



Splash Guard **OPTION**

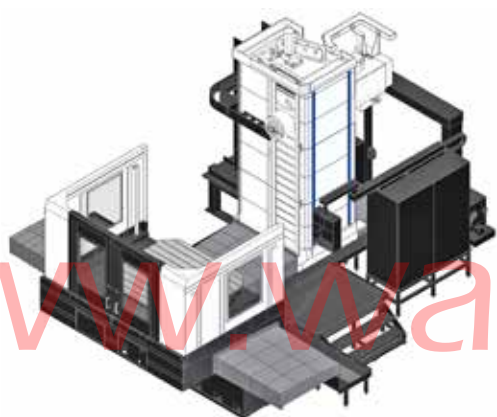

A-Type Table Around Cover

KBN135 : ○ KBN135C : ○
※ Cannot open or close on KBN135

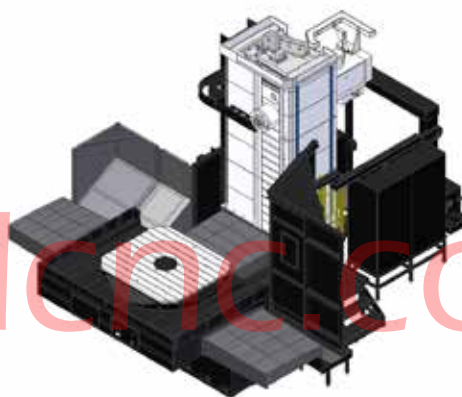

B-Type Coolant Protect Cover

KBN135 : X, KBN135C : ○

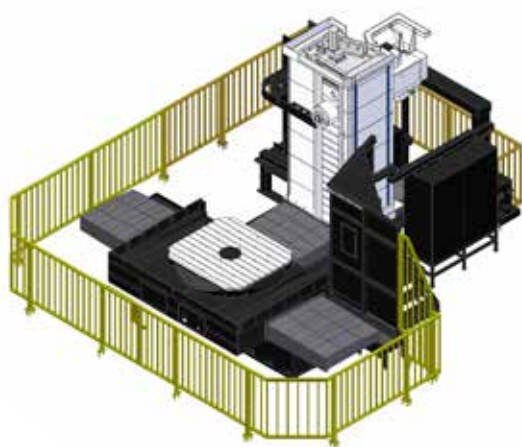

C-Type Safety Fence

KBN135 : ○, KBN135C : ○

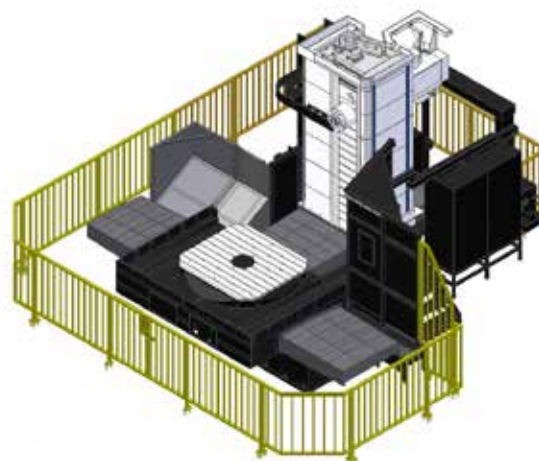

D-Type B+C Type

KBN135 : X, KBN135C : ○

www.wardenc.com

SPECIFICATIONS

Standard & Optional

Spindle		KBN135	KBN135C
2,000rpm (22/18.5kW[29.5/24.8HP])	FANUC	●	-
2,000rpm (26/22kW[34.8/29.5HP])	FANUC	○	-
2,000rpm (37/30kW[49.6/40.2HP])	FANUC	○	-
2,500rpm (22/18.5kW[29.5/24.8HP])	FANUC	-	●
2,500rpm (26/22kW[34.8/29.5HP])	FANUC	-	○
2,500rpm (37/30kW[49.6/40.2HP])	FANUC	-	○
2,500rpm (37/31kW[49.6/41.6HP])	SIEMENS	-	○
Spindle Cooling System		●	●
W Axis Support Sleeve		○	○
ATC			
ATC Extension	40	●	●
	60	○	○
	90	○	☆
	120	○	☆
Tool Shank Type	BT50	●	●
	CAT50	○	○
Heavy Weight Tool U-Center	25kg (55lb)	○	○
	D'andrea	☆	☆
Pull Stud	45°	●	●
	60°	☆	☆
	90°	☆	☆
Facing Head		○	○
Facing Tool Holder (Facing heads when applying)		○	○
Telescopic Tool Holder (Facing heads when applying)		○	○
Angle Head	500mm(19.7")	○	○
	800mm(31.5")	○	○
Auto Indexing Head	730mm(28.7")	☆	☆
Table & Column			
T-Slot Table		●	●
B Axis Table	0.001°	●	●
X Axis Extension	4,000mm(157.4")	○	○
Y Axis Extension	2,500mm(98.4")	○	○
Z Axis Extension	2,000mm(78.7")	-	○
Index Pin (4x90')		●	●
Table Auto Clamp Device		●	●
Coolant System			
Coolant Device		○	○
Through Spindle Coolant*	20 bar (290 psi)	○	○
	30 bar (435 psi)	-	-
Gun Coolant (Only for Coolant Device)		○	○
Air Gun		○	○
Cutting Air Blow		○	○
Tool Measuring Air Blow (Only for TLM)		○	○
Coolant Chiller (Only for Coolant Device)		☆	☆
Chip Disposal			
Coolant Tank	400 ℓ (105.7 gal)	-	○
	500 ℓ (132 gal)	○	-
Cabin Screw Chip Conveyor		●	●
Cabin Hinge Chip Conveyor		-	○
Chip Conveyor (Hinge/Scraper)	Left(Front)	○	-
	Left(Rear)	○ (60 Tool : -)	-
-Only for Coolant Device		○	○
Chip Wagon	Standard (180 ℓ [47.5 gal])	○	○
	Swing (200 ℓ [52.8 gal])	○	○
	Large Swing (290 ℓ [76.6 gal])	○	○
	Large Size (330 ℓ [87.2 gal])	○	○
	Customized	☆	☆

● : Standard ○ : Option ☆ : Prior Consultation - : Non applicable

S/W		KBN135	KBN135C
Machine guidance (HW-MCG) : FANUC/SIEMENS		☆	☆/-
Tool Monitoring (HW-TM)		○	○
DNC Software (HW-eDNC)		○	○
Spindle Heat Distortion Compensation (HW-TDC)		○	○
Spindle Warm up Function (HW-WARMUP) : FANUC/SIEMENS		☆	☆/-
Energy Saving System (HW-ESS) : FANUC/SIEMENS		☆	☆/-
Machine Monitoring System (HW-MMS)		○	○
Tool Offset Measurement (HW-TOM)		☆	☆
Machining Condition Selection (HW-MCS) : FANUC/SIEMENS		☆	☆/-
Adaptive Feed Control (HW-AFC) : FANUC/SIEMENS		☆	☆/-
Conversational Program (HW-DPRO)		○	○
Safety Device			
Front Full Cover		●	●
Table Around Cover (Only for Thru. Coolant)		○	○
Extension Table Around Cover		☆	☆
Safety Fence		○	○
Electric Device			
Call Light	1 Color : ■	●	●
Call Light	2 Color : ■ ■	○	○
Call Light	3 Color : ■ ■ ■	○	○
Call Light & Buzzer	3 Color : ■ ■ ■ B	○	○
Work Light		●	●
Electric Cabinet Light		○	○
Remote MPG		●	●
3 Axis MPG		○	○
Work Counter	Digital	○	○
Total Counter	Digital	○	○
Tool Counter	Digital	○	○
Multi Tool Counter	6 EA	○	○
	9 EA	○	○
Electric Circuit Breaker		○	○
AVR (Auto Voltage Regulator)		☆	☆
Transformer	50kVA	○	○
	60kVA	○	○
Auto Power Off		○	○
Back up Module for Black out		○	○
Measuring Device			
Air Zero		○	○
TLM	Touch	○	○
(Marposs/Renishaw/Blum)	Laser	○	○
Tool Broken Detecting Device		☆	☆
Linear Scale	X/Y/Z Axis	●	●
Rotary Scale	B Axis	●	●
Coolant Level Sensor		☆	☆
Environment			
Air Conditioner		○	○
Dehumidifier		○	○
Oil Mist Collector		☆	☆
Oil Skimmer (Only for Chip Conveyor)		○	●
MQL (Minimal Quantity Lubrication)		☆	☆
Fixture & Automation			
Sub O/P		☆	-
Control of Additional Axis	1Axis	☆	☆
	2Axis	-	-
External M Code 4ea		○	○
I/O Extension (In & Out)	16 Contact	○	○
	32 Contact	○	○
Hyd. Device			
Std. Hyd. Unit	45bar (652.7 psi) / 200 ℓ (52.8 gal)	●	●
Center Hyd. Supply Device		-	-
Hyd. Unit for Fixture	45bar (653psi)	☆	☆
	70bar (1,015psi)	☆	☆
	100bar (1,450 psi)	☆	☆
	Customized	☆	☆
ETC			
Tool Box		●	●
CAD&CAM Software	Need for Munsel No.	☆	☆
Customized Color		☆	☆
W Axis Clamp Device		●	●
Y Axis Clamp Device		●	●

Through Spindle Coolant* : Please check the filter types with sales representative.
Specifications are subject to change without notice for improvement.

SPECIFICATIONS

External Dimensions

unit : mm(in)

KBN135 (Expand Option)

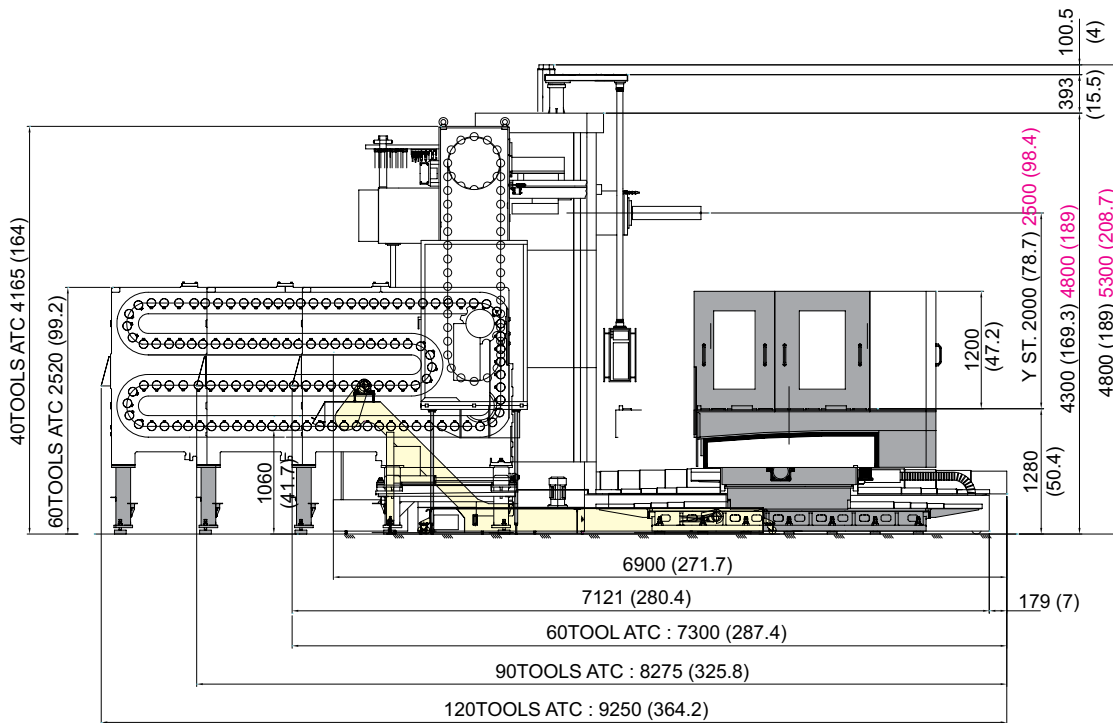
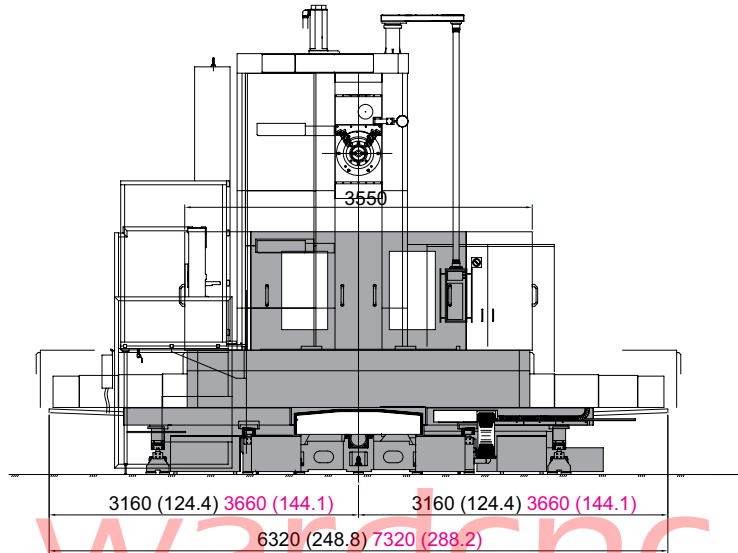

www.wardcnc.com

SPECIFICATIONS

External Dimensions

unit : mm(in)

KBN135C (Expand Option)

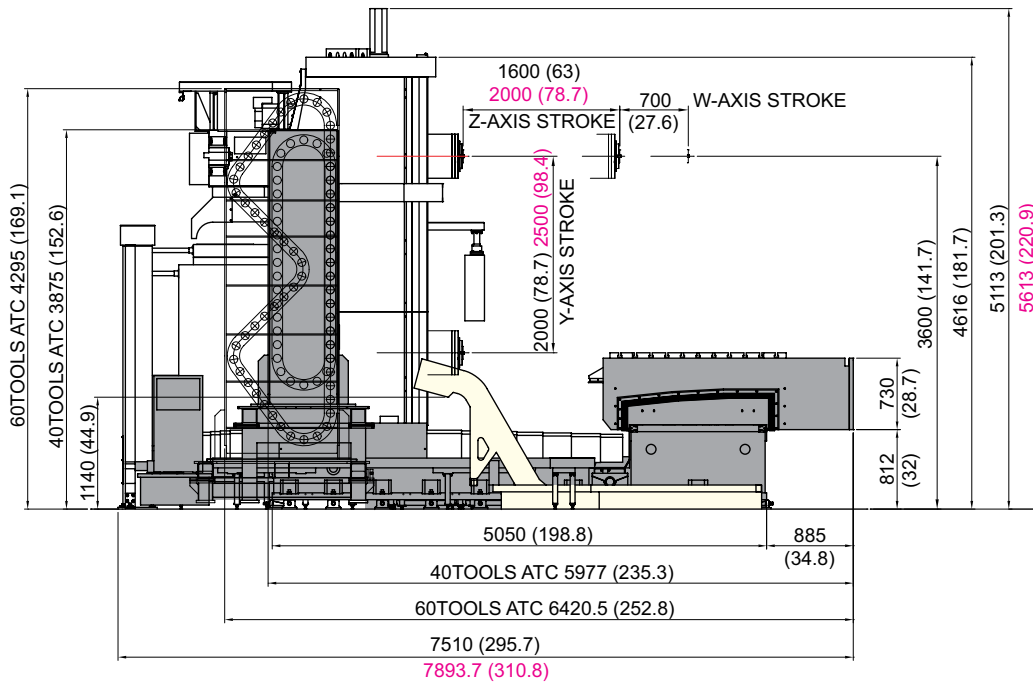
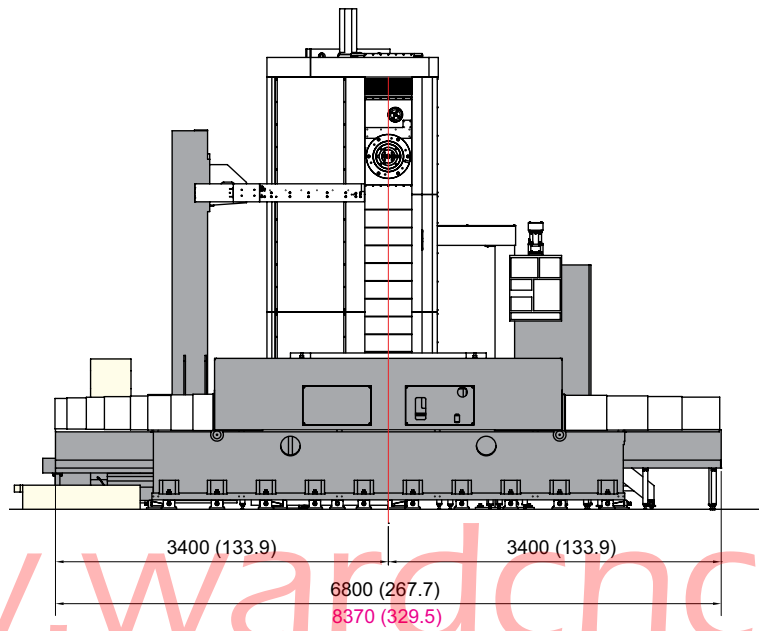

Height when upper hydraulic supply device is attached: 3,845mm (151.4")

SPECIFICATIONS

Table Dimensions

unit : mm(in)

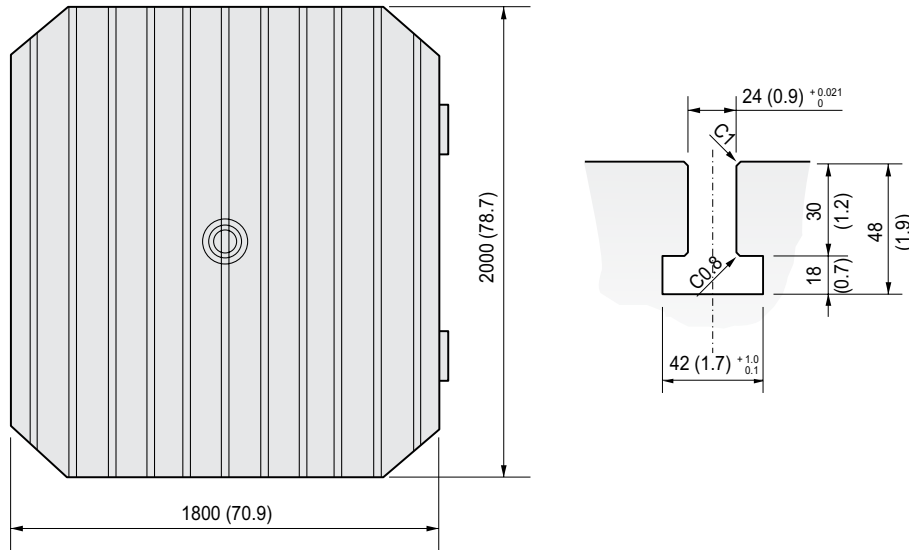

Tool Shank

unit : mm

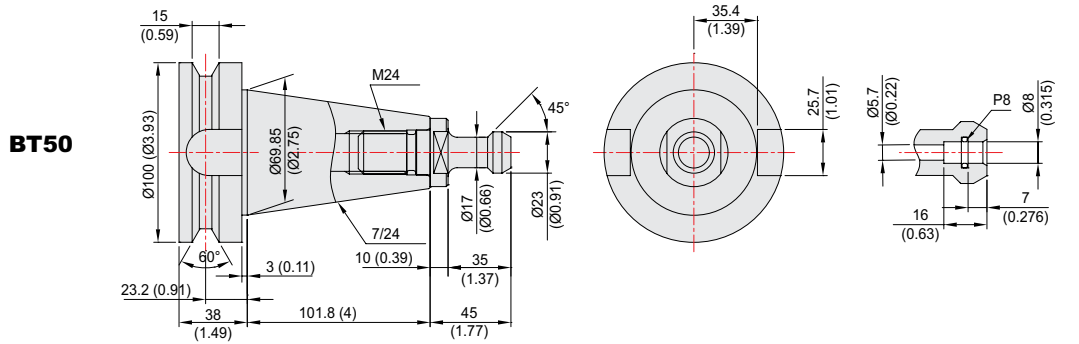

CAT-50

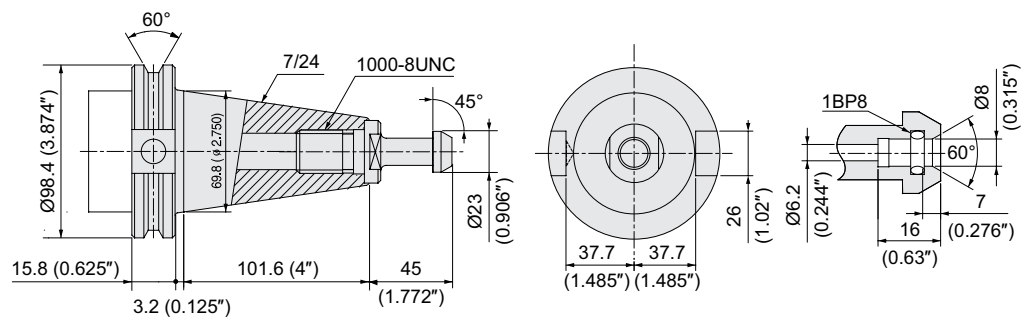

SPECIFICATIONS

Specifications

[] : Option

ITEM			KBN135	KBN135 (Expand Option)	KBN135C	KBN135C (Expand Option)	
TABLE	Table Size	mm(in)	2,000×1,800 (78.7"×70.9")				
	Maximum Load Capacity	kgf(lb)	10,000 (22,046.2)		❖ 15,000 (33,069.3)	❖ 20,000 (44,092.4)	
	Min. Indexing Angle	deg	0.001° / 90° (LOCATING PIN)				
SPINDLE	Spindle Quill Diameter	mm	Ø135 (5.3")				
	Spindle Taper	-	NT #50				
	Spindle Speed (rpm)	r/min	2,000 [2,000] [2,000]		2,500 [2,500] [2,500] [2,500]		
	Spindle Power (Max./Cont.)	kW(HP)	22/18.5 (29.5/24.8) [26/22 (34.9/29.5)] [37/30 (49.6/40.2)]		22/18.5 (29.5/24.8) [26/22 (34.9/29.5)] [37/30 (49.6/40.2)] [37/31 (49.6/41.6)]		
	Spindle Torque(Max./Cont.)	N·m(lbf·ft)	3,112/2,617 (2,295.3/1,930.2) [3,677/3,112 (2,712/2,295.3)] [6,824/5,538 (5,033.1/4,084.6)] [KBN135C : 6,862/5,717 (5,061.2/4,216.6)]				
	Spindle Driving Method	-	3 STEP GEAR				
FEED	Travel	X-axis	mm(in)	3,000 (118.1")	4,000 (157.5")	3,000 (118.1")	4,000 (157.5")
		Y-axis	mm(in)	2,000 (78.7")	2,500 (98.4")	2,000 (78.7")	2,500 (98.4")
		Z-axis	mm(in)	1,600 (63")		2,000 (78.7")	
		W-axis	mm(in)	700 (27.6")			
	Distance from Column to SP. center	mm(in)	0 ~ 2,000(78.7")	0 ~ 2,500(98.4")	0 ~ 2,000(78.7")	0 ~ 2,500(98.4")	
	Distance from Table Surface to SP	mm(in)	800 ~ 2,400(31.5"~94.5")			800 ~ 2,800 (31.5"~110.2")	
	Rapid Traverse Rate (X/Y/Z/W)	m/min(ipm)	8/8/8/8 (315/315/315/315)		10/10/10/8 (393.7/393.7/393.7/315)	7/10/10/8 (275.6/393.7/393.7/315)	
Slide Type	-	BOX GUIDE					
ATC	Number of Tools	EA	40 [60, 90, 120]		40 [60]		
	Tool Shank	-	BT50				
	Max. Tool Dia. (W.T/W.O)	mm(in)	Ø125/Ø250 (4.9"/9.8")				
	Max. Tool Length	mm(in)	600 (23.6")				
	Max. Tool Weight	kg(lb)	20 [25] (44.1 [55.1])				
	Tool Selection Method	-	FIXED ADDRESS				
	Tool Change Time	T-T	sec	30		22.4	30
		C-C	sec	70		33.2	70
TANK CAPACITY	Coolant Tank	ℓ (gal)	500 (132.1)		400 (105.7)		
	Lubricating Tank	ℓ (gal)	8.5 (2.2)				
	Hydraulic Tank	ℓ (gal)	200 (52.8)				
POWER SUPPLY	Air Consumption (0.5MPa)	ℓ /min(gal/min)	250 (66)				
	Electric Power Supply	KVA	42				
	Thickness of Power Cable	Sq	Over 50				
	Voltage	V/Hz	220/60 (200/50*)				
MACHINE	Floor Space (L×W)	mm(in)	6,320×6,900 (248.8"×271.7")	7,320×6,900 (288.2"×271.7")	6,880×7,510 (270.9"×295.7")	8,370×7,910 (329.5"×311.4")	
	Height	mm(in)	4,793 (188.7")	5,293 (208.4")	5,113 (201.3")	5,613 (221")	
	Weight	kg(lb)	37,200 (82,012)	44,000 (97,003)	46,500 (102,515)	52,000 (114,640)	
NC	Controller	-	FANUC 31i-B		FANUC 31i-A [SIEMENS 840D sl]		

❖ within 300mm(11.8") of the biased weight

*) Using 50Hz voltage instead of 60Hz may lower the output of motors. (excluding servo motors and inverter motors)

Specifications are subject to change without notice for improvement.

CONTROLLER

FANUC 31i-B (KBN135)

☆ Needed technical consultation

Controlled axis / Display / Accuracy compensation	
Control axes	5 axes (X, Y, Z, W, B)
Simultaneously controlled axes	4 axes
Least setting Unit	X, Y, Z axes : 0.001 mm (0.0001 inch) B axes : 0.001 deg
Least input increment	X, Y, Z axes : 0.001 mm (0.0001 inch) B axes : 0.001 deg
Inch / Metric conversion	G20 / G21
High response vector control	
Interlock	All axes / Each axis
Machine lock	All axes
Backlash compensation	± 0 ~ 9999 pulses (Rapid traverse / Cutting feed)
Position switch	
LCD / MDI	10.4 inch color LCD
Feedback	Absolute motor feedback
Stored stroke check 1	Over travel
Stored pitch error compensation	
Operation	
Automatic operation (Memory)	
MDI operation	
DNC operation	Needed DNC software / CF card
Program restart	
Wrong operation prevention	
Program check function	Dry run, Program check Z axes Machine lock, Stroke check before move
Single block	
Search function	Program Number / Sequence Number
Interpolation functions	
Pano interpolation	
Positioning	G00
Linear interpolation	G01
Cylindrical interpolation	G02, G03
Exact stop mode	Single : G09, Continuous : G61
Dwell	G04, 0 ~ 9999.9999 sec
Skip	G31
Reference position return	1st reference : G28 2nd reference : G27 Ref. position check : G30
Thread synchronous cutting	G33
Helical interpolation	Circular + Linear interpolation 2 axes(max.)
Feed function / Acc. & Dec. control	
Manual feed	Rapid traverse Jog : 0~5,000mm/min (197 ipm) Manual handle : x1, x10, x100 pulses Reference position return
Cutting feed command	Direct input F code
Feedrate override	0 ~ 200% (10% Unit)
Rapid traverse override	F0% (F1%), F25%, F50%, F100%
Override cancel	
Feed per minute	G94
Feed per revolution	G95
Look-ahead block	40 Block 200 Block (Mold)
Program input	
Tape Code	EIA / ISO
Optional block skip	1 ea
Absolute / Incremental program	G90 / G91
Program stop / end	M00, M01 / M02, M30
Maximum command unit	± 999,999.999 mm (± 99,999.9999 inch)
Plane selection	X-Y : G17 / Z-X : G18 / Y-Z : G19
Workpiece coordinate system	G52, G53, 48 pairs (G54.1 P1 ~ 48)
Manual absolute	Fixed ON
Programmable data input	G10
Sub program call	10 folds nested
Custom macro	#100 ~ #149, #500 ~ #549
G code system	A
Programmable mirror image	G51.1, G50.1
G code preventing buffering	G4.1
Including Chamfering / Corner R	
Canned cycle	G73, G74, G76, G80 ~ G89
Coordinate rotation	G68, G69

Auxiliary function / Spindle speed function	
Auxiliary function	M & 4 digit
Level-up M Code	Multi / Bypass M code
Spindle speed command	S & 5 digit , Binary output
Spindle override	0% ~ 150% (10% Unit)
Spindle orientation	M19
FSSB high speed rigid tapping	
Tool function / Tool compensation	
Tool function	Max. T 8 digit
Tool life management	256 pairs ☆
Tool offset pairs	99 pairs
Tool nose radius compensation	G40, G41, G42
Tool nose length compensation	G43, G44, G49
Tool offset memory C	Tool length, diameter, abrasion(length, diameter)
Tool length measurement	Z axes Input C
Editing function	
Part program storage size	640m (256KB)
No. of registerable programs	1000 EA
Program protect	
Background editing	
Extended part program editing	Copy, move and change of NC program
Memory card program edit	
Data input / output & Interface	
I/O interface	RS 232C serial port, CF card, USB memory Embedded Ethernet interface
Screen hard copy	
External message	
External key input	
External workpiece number search	
Automatic data backup	
Setting, display and diagnosis	
Self-diagnosis function	
History display	Alarm & Operator message & Operation
Run hour / Parts count display	
Maintenance information	
Actual cutting feedrate display	
Display of spindle speed / T code	
Graphic display	
Operating monitor screen	Spindle / Servo load etc.
Power consumption monitoring	Spindle & Servo
Spindle / Servo setting screen	
Multi language display	Support 20 languages
Display language switching	Selection of 5 optional Languages
LCD Screen Saver	Screen saver
Processing select	Speed/ridigity setting
Option	
Additional optional block skip	9 ea ☆
Fast ethernet	Needed option board
Data server	Needed option board
Protection of data at 8 levels	
Sub Spindle control	
Polar coordinate command	G15, G16
Polar coordinate interpolation	G12.1, G13.1
Cylindrical interpolation	G07.1
One-way positioning	G60
Stored stroke check 2, 3	
Inverse-time feed	G93
Scaling	G50, G51
Manual guide i	Conversational auto program
Handle interrupt	
Manual handle feed	2/3 units
Additional custom macro variables	#100~#199, #500~#999 #100~#199, #500~#999, #98000~#98499
Retraction for rigid tapping	
Tool management function	
Tool offset number	Max. 2000 pair ☆
Program storage capacity	512KB ~ 8MB ☆
Program registration number	Max. 4000 ea ☆
Additional work coordinate	Max. 300 pair (G54.1 P1 ~ P300)
AICC II	200 block 400 / 600 / 1000 block ☆

Figures in inch are converted from metric values.

The FANUC controller specifications are subject to change based on the policy of company CNC supplying.

CONTROLLER

FANUC 31i-A (KBN135C)

Axis control / Display unit	
Controlled axis	5 axes (X, Y, Z, B, W)
Simultaneous controllable axis	4 axes
Least input increment	X, Y, Z axis : 0.001mm (0.0001") B axis : 0.001deg
Least command increment	X, Y, Z axis : 0.001mm (0.0001") B axis : 0.001deg
Inch / Metric conversion	G20 / G21
Interlock	Each axis / All axis
Machine lock	All axis
Emergency stop	
Stored stroke check 1	Over-travel
Follow-up	
Servo off	
Backlash compensation	+/- 0~9999 pulse (rapid traverse & cutting feed)
Position switch	
Stored pitch error compensation	
LCD/MDI	10.4" color LCD
Operation	
Automatic operation (memory)	
MDI operation	
DNC operation	Need DNC Program
Program restart	
Wrong operation prevention	
Buffer register	
Program check function	Dry run, program check
Single block	
Feed functions	
Manual jog feed	Rapid, Jog, handle
Manual handle feed-rate	x1, x10, x100
Feed command	F code feedrate direct command
Feedrate override	0~200% (10% Unit)
Jog feed	0~5,000mm/min (197ipm)
Rapid traverse override	F0,F1,F25%,F50%,F100%
Override cancel	
Rapid traverse bell-shaped acceleration/deceleration	
Program input & Interpolation functions	
AI contour control(AICC)	40 Block
Label Skip	
Control in/out	
Piano Interpolation	Positioning/Linear/Circular (G00/G01/G02/G03)
Exact stop mode/Exact stop	G61 / G09
Dwell	G04, 0~9999.9999 sec
Helical interpolation	
Threading/synchronous feed	G33
Manual reference point return	
Reference point return	G28
Reference point return check	G27
2nd, 3rd, 4th Reference point return	G30
Program stop/end	M00, M01 / M02, M30
Tape code	EIA / ISO Automatic recognition
Optional block skip	1 ea
Max. programmable dimensions	+/- 9999.9999" (+/- 8 digits)
Program number	04 / N8
Absolute/incremental command	G90 / G91
Decimal point input	
Plane selection	G17, G18, G19
Work coordinate preset	G52~G59
Additional work coordinate system	G54.1 P1~P48 (48 pair)
Manual absolute	"On" fixed
Programmable data input	G10
Sub program call	10 folds nested
Custom macro	
Circular interpolation	G02, G03
Canned cycle	G73, G74, G76, G80 ~ G89
Optional chamfering/corner R	

Program input & Interpolation functions	
Skip function	G31
Automatic coordinate system setting	
Coordinate system rotation	G68, G69
Programmable mirror image	G50.1, G51.1
Sub / Spindle functions	
Miscellaneous function	M4 digit
Miscellaneous function lock	
Spindle speed command	S5 digits, binary output
Spindle speed override	50% ~ 150% (10% Unit)
Spindle orientation	
Rigid tapping	
Tool functions / Tool compensation	
Tool function	Max. T8 digits
Cutter compensation C	G40~G42
Tool length measurement	Z axis INPUT C
Tool length compensation	G43, G44, G49
Tool offset pairs	99 pair
Tool life management	
Data input / Output & Editing functions	
Reader/Puncher interface	RS232C
Memory card input/output	
Embedded Ethernet	100Mbps
Part program storage length	640m (256Kbyte)
Registered programs	1000 ea
Memory lock	
Back ground editing	
Extended part program editing	Copy, move, change of NC program
External message	
Setting, display, diagnosis	
Self-diagnosis function	
History display	Alarm & operator message
Help function	
Run hour/Parts count display	
Actual cutting feedrate display	
Graphic display	
Operation monitor screen	
Spindle/Servo setting screen	
Multi-language display	Selection of 5 optional language
LCD Screen Save	Screen saver
Auto Data Backup	
Option	
Sub Axis Control	
Work coordinate Command	G15, G16
Work coordinate Interpolation	G12.1, G13.1
Helical interpolation	G07.1
Single direction positioning	G60
External data input	Tool offset/message/machine zero point shift
FAST ethernet	100 Mbps
Additional work coordinate system	300 pair
Scaling	
FS 15 Tape format	
Tool offset number	200 pair
Part program storage length	Max. 1000 ea
High Speed Skip Function	
Data server	1GB
AI contour control(AICC)	200 Block/Select the machining conditions
AI contour control(AICC) 1	600 Block/Select the machining conditions Data Server/Automatic shut-off device
AI contour control(AICC) 2	1000 Block/Select the machining conditions Data Server/Automatic shut-off device
Manual Guide i	Conversational program
Optional Blockskip	9 ea (Application can be limited)
Handle interrupt	
3 axis MPG	
program storage length	640m (256Kbyte) / 5120m (2Mbyte)
Protection of data at 8 levels	
Additional custom micro change	#100 ~ #199, #500 ~ #999

Figures in inch are converted from metric values.

The FANUC controller specifications are subject to change based on the policy of company CNC supplying.

CONTROLLER

SIEMENS 840D sl (KBN135C)

Control Function

Max. configuration of axis	Max 5-axes (Max. 31 Axes)
Max. configuration of axis and sp.	Max 5-axes (Max. 31 Axes)
Least Command/input	0.001mm / 0.0001inch

Feed Function

Feedrate Override	0 - 120%
Rapid Traverse Override	F0, 25, 50, 100%

Tool Function

Tool Radius Comp.	
Zero Offset (G54, G55, G56, G57, G58, G59)	6EA (MAX:100EA)
Programmable Zero Offset	
3D Tool Radius Compensation	

Display

Language	Chinese Simplified, English, French German, Italian, Spanish
CRT/MDI	TFT 10.4" Color
Screen saver	
Travel to fixed stop	

Spindle Function

Spindle Override	50% - 120%
Spindle Orientation	
Spindle Speed Limitation	
Rigid Tapping	

Manual Operation

Manual Handle/Jog Feed	
Reposition	
Reference Approach	Ref 1, 2 Approach
Spindle Control	Start, Stop, Rev, Jog, Ort.

Auto Operation

Single Block	
Feed Hold	
Optional Block Skip	
Machine Lock	
Dry Run	
Simulation	

Diagnosis Function

Alarm Display	
Spindle Load Meter/RPM Meter (monitor)	

Programming Function

Part Program Storage Length	3MB(7500M) **Additional CF card (512MB) possible
Program Name	23 digits
Subroutine Call	7Level
Absolute/incremental Command	G90 - G91

Programming Input & Interpolation Function

Scaling / Rotation	
Inch / Metric Conversion	
Conversational Cycle Program	
Block Search	
Macro	
Read/Write System Variable	
BackGround Editing	
Miscellaneous Functions	M - Code
Skip	
Program Stop	M00, M01, M02, M30
Lookahead, Jerk Limitation Feed & Forward Control	
Helical interpolation	
COMPCAD, COMPCURB	
Cylindrical interpolation	
Work Coordinate interpolation	
Interactive Program	
Fanuc Program exe.	
Machining Package Milling	

Protection Function

Emergency Stop	
Soft Limit / Over Travel	Soft Limit & Hard O.T
Contour Monitoring	
Program Protection	

Automation Support Fun.

Actual Speed Display (Monitor)	
Tool Life Management	(Time, Parts)
Work Count	(Internal)

Language

Two Language Switchable	(6EA) Chinese Traditional, Czech, Danish, Dutch, Finnish, Hungarian, Japanese, Korean, Polish, Russian, Swedish, Portuguese, Turkish
-------------------------	--

DATA Transfer

RS 232C I/F	
Ethernet	Network management software is necessary

Option

PCU50	With Harddisk
USB Memory Stick (Only PCU50)	Only PCU50
Lan Flash PCU20 (Only Flash Card 512MB)	Network management software, Spline interpolation is standard
Temperature Compensation	

GLOBAL NETWORK



Hyundai WIA
Machine Tools America



Hyundai WIA
Machine Tools Europe
Rauheim Service Center
Rauheim R&D Center

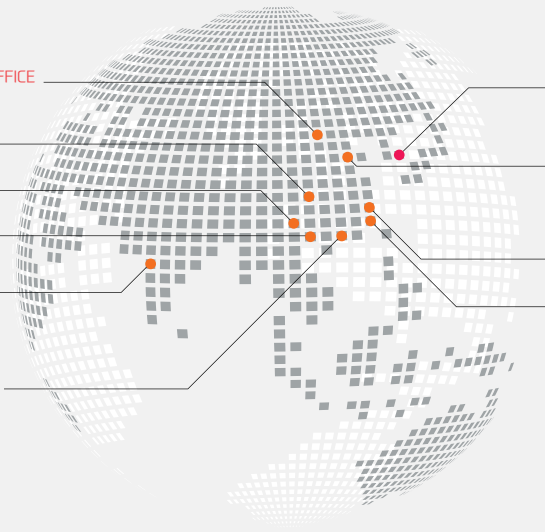

BEIJING BRANCH OFFICE
WUHAN OFFICE
CHENGDU BRANCH OFFICE
CHONGQING OFFICE
INDIA BRANCH OFFICE
GUANGZHOU BRANCH OFFICE
HEADQUARTER
QINGDAO BRANCH OFFICE
JIANGSU HYUNDAI WIA
Hyundai WIA Machine Tools China
SHANGHAI BRANCH OFFICE

www.wardenc.com

GLOBAL NETWORK



HEADQUARTER

Changwon Technical Center / R&D Center / Factory

153, Jeongdong-ro, Seongsan-gu, Changwon-si,
Gyeongsangnam-do, Korea (Zip Code : 51533)
TEL : +82 55 280 9114 FAX : +82 55 282 9680

Uiwang Technical Center / R&D Center

37, Cheoldobangmulgwan-ro, Uiwang-si, Gyeonggi-do,
Korea (Zip Code : 16082)
TEL : +82 31 596 8209 Fax : +82 55 210 9804

OVERSEAS OFFICES

HYUNDAI WIA Machine Tools America

265, Spring Lake Drive, Itasca, IL, 60143
TEL : +1 630 625 5600
FAX : +1 630 625 4733

Jiangsu HYUNDAI WIA

Company No.6 Fenghuang Road,
Fenghuang Town, Zhangjiagang City,
Jiangsu province, China
TEL : +86 512 5672 6808
FAX : +86 512 5671 6960

Chengdu Branch Office

NO.508 Room, B Block, AFC Plaza, NO.88
Jiaozi Road, High-tech Zone, Chengdu,
China
TEL : +86 028 8665 2985
FAX : +86 028 8665 2985

HYUNDAI WIA Machine Tools Europe

Kaiserleipromenade 5, 63067 Offenbach,
Germany
TEL : +49 69271 472 701
FAX : +49 69271 472 719

Hyundai WIA Machine Tools China Shanghai Branch Office

1-3F, Bldg6, No.1535 Hongmei Road,
Xuhui District, Shanghai, China
TEL : +86 021 6427 9885
FAX : +86 021 6427 9890

Qingdao Branch Office

Room 1207, Cai Fu Building, 182-6 Haier
Middle Road, Qingdao, China
TEL : +86 532 8667 9334
FAX : +86 532 8667 9338

Raunheim Service Center Raunheim R&D Center

Frankfurter. 63, 65479 Raunheim,
Germany
TEL : +49 6142 9256 111
FAX : +49 6142 9256 100

Beijing Branch Office

Floor 14, Zhonghangji Plaza B, No.15
Ronghua South Road, BDA Dist., Daxing
Dist., Beijing, China 100176
TEL : +86 010 8453 9850
FAX : +86 010 8453 9853

Wuhan Office

306-2, A Tower, Jiayu Gpmggian, No12
Chuangye Road, Economic Development
Zone, Wuhan, Hubei, China
TEL : +86 027 5952 3256
FAX : +86 027 5952 3256

India Branch Office

#4/169, Rajiv Gandhi Salai, (OMR),
Kandanchavadi, Chennai-600 096,
Tamilnadu, India
TEL: +91-44-3290-1719

Guangzhou Branch Office

Room 311, Unit 1-3, POLY TAL TU WUP,
Hanxi Avenue, Panyu District, Guangzhou,
China
TEL : +86 020 8550 6595
FAX : +86 020 8550 6597

Chongqing Office

Room 951, #3, Jinrongcheng T3, Jiangbei,
Chongqing, China
TEL : +86 23 6701 2970

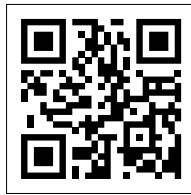

KBP135 Movie

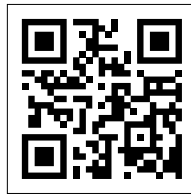

KBP135C Movie

www.wardcnc.com



<http://machine.hyundai-wia.com>

Head Office & Factory

153, Jeongdong-ro, Seongsan-gu, Changwon-si, Gyeongsangnam-do **Tel** +82 55 280 9500

Overseas Sales Team

16F, 37, Cheoldobangmulgwan-ro, Uiwang-si, Gyeonggi-do **Tel** +82 31 593 8173

HYUNDAI WIA Machine Tools America

265 Spring Lake Drive, Itasca, IL, 60143 **Tel** +1 (630) 625 5600 **Fax** +1 (630) 625 4733

HYUNDAI WIA Machine Tools Europe

Kaiserleipromenade 5, D-63067 Offenbach, Germany **Tel** +49 69271 472 701 **Fax** +49 69271 472 719

India Branch Office

#4/169, Rajiv Gandhi Salai, (OMR), Kandanchavadi, Chennai-600 096, Tamilnadu, India **Tel** +91 44 3290 1719